

Eclipse RatioAir Burners

Model RA0500

Version 1

Main Specifications - RA0500

PARAMETER		SPECIFICATIONS		
		Straight Tube	Medium Velocity Tube	High bVelocity Tube
Maximum input, Btu/hr (kW) at neutral chamber conditions 60Hz Packaged Blower	Natural Gas	5,500,000 (1610)	5,300,000 (1552)	5,100,000 (1493)
	Propane	5,500,000 (1610)	5,100,000 (1495)	4,600,000 (1348)
	Butane	5,400,000 (1583)	5,000,000 (1465)	5,100,000 (1495)
Maximum input, Btu/hr (kW) at neutral chamber conditions 50Hz Packaged Blower	Natural Gas	5,580,000 (1633)	5,375,000 (1574)	5,250,000 (1537)
	Propane	5,580,000 (1633)	5,170,000 (1514)	4,740,000 (1388)
	Butane	5,480,000 (1604)	5,070,000 (1485)	5,250,000 (1537)
Minimum input, Btu/hr (kW) • Lower inputs may be achieved. Contact factory.		100,000 (29)	100,000 (29)	100,000 (29)
Main Gas Inlet Pressure, "w.c. (mbar) • Fuel pressure at ratio regulator inlet.		15 to 55 (38 to 137)	15 to 55 (38 to 137)	20 to 55 (50 to 137)
High Fire Flame Length, inches (mm) • Measured from the outlet end of the combustor.		100 (2550)	97 (2464)	75 (1900)
Maximum Flame Velocity, ft/s (m/s) • Approximately 15% excess air at maximum input.		-----	250 (75)	500 (150)
Maximum chamber temperature, °F (°C)	Alloy tube	1500 (816)	1750 (954)	1750 (954)
	Block & Holder	1900 (1038)	2800 (1538)	2800 (1538)
Flame detection		UV scanner only		
Fuel		Natural Gas (For any other gas, contact Eclipse Combustion for orifice sizing.)		

- All information is based on laboratory testing in neutral (0.0" w.c.) chamber with standard combustor design. Different chamber conditions will affect the data.
- Maximum inputs are given for the standard combustion air blower without an air filter.
- All inputs based upon gross calorific values and standard conditions: 1 atmosphere, 70° F (21°C).
- Blower motor service factors greater than 1.0 may be required when firing into negative chamber pressure applications. For specific application questions, contact your Eclipse Combustion representative.
- Eclipse reserves the right to change the construction and/or configuration of our products at any time without being obliged to adjust earlier supplies accordingly.

Control and Operation Zone

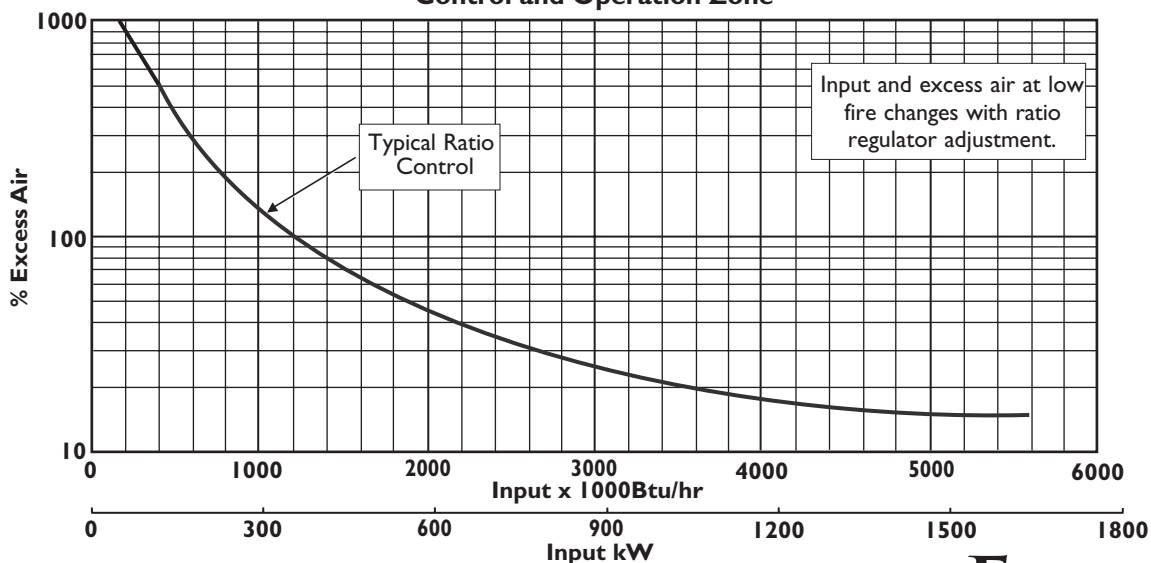

Straight Tube Specifications

Blower Model

60Hz, 6B (10" w.c. @ 66,000 scfh, 3 hp)
 50Hz, 6B (10" w.c. @ 66,000 scfh, 2.2 kW)

Specifications						
Parameter	"w.c. (mbar)		60Hz Packaged Blower		50Hz Packaged Blower	
	"w.c.	(mbar)	Btu/hr	kW	Btu/hr	kW
Maximum Input vs. Chamber Pressure (Natural Gas)	-2.0	-5,0	6,160,000	1804	6,100,000	1786
	-1.0	-2,5	5,900,000	1728	5,850,000	1713
	0.0	0,0	5,500,000	1634	5,580,000	1633
	1.0	2,5	5,340,000	1564	5,300,000	1552
	2.0	5,0	5,030,000	1473	5,010,000	1467

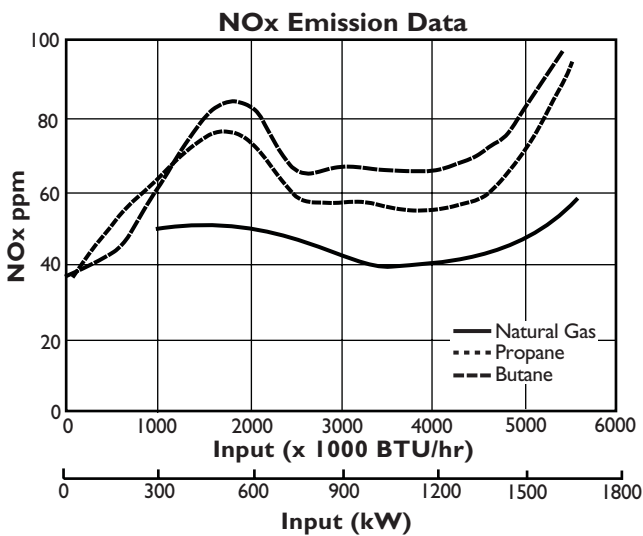

NOx emission data is given for:

- Ambient combustion air ~70°F (20°C)
- Less than 1000°F (538°C firing chamber)
- Minimal process air velocity
- ppm volume dry at 3% O₂
- Neutral chamber pressure

CO emission is largely influenced by chamber conditions. Contact your local Eclipse Combustion representative for an estimate of CO emission on your application.

Emissions are influenced by:

- Chamber conditions
- Fuel type
- Firing rate
- Ratio regulator adjustment
- Combustion air temperature

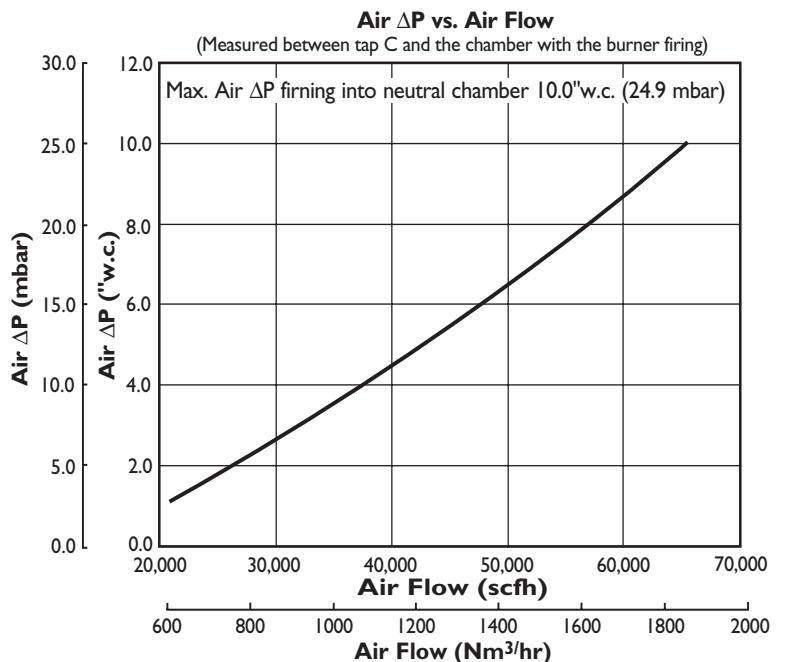
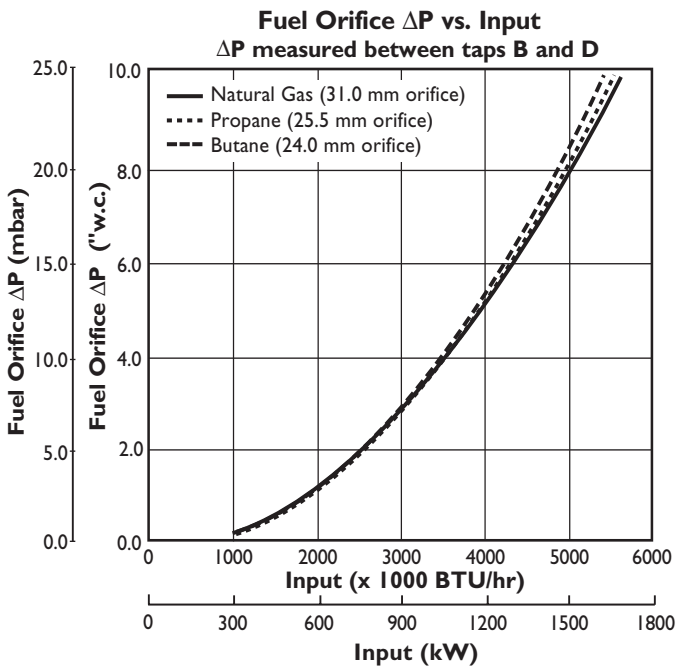

Medium Velocity Tube Specifications

Blower Model

60Hz, 6B (10" w.c. @ 66,000 scfh, 3 hp)

50Hz, 6B (10" w.c. @ 66,000 scfh, 2.2 kW)

Specifications						
Parameter	"w.c. (mbar)		60Hz Packaged Blower		50Hz Packaged Blower	
			Btu/hr	kW	Btu/hr	kW
Maximum Input vs. Chamber Pressure (Natural Gas)	-2.0	-5.0	5,796,000	1697	5,840,000	1710
	-1.0	-2.5	5,563,000	1629	5,610,000	1643
	0.0	0.0	5,300,000	1558	5,325,000	1574
	1.0	2.5	5,065,000	1483	5,125,000	1501
	2.0	5.0	4,797,000	1405	4,860,000	1423

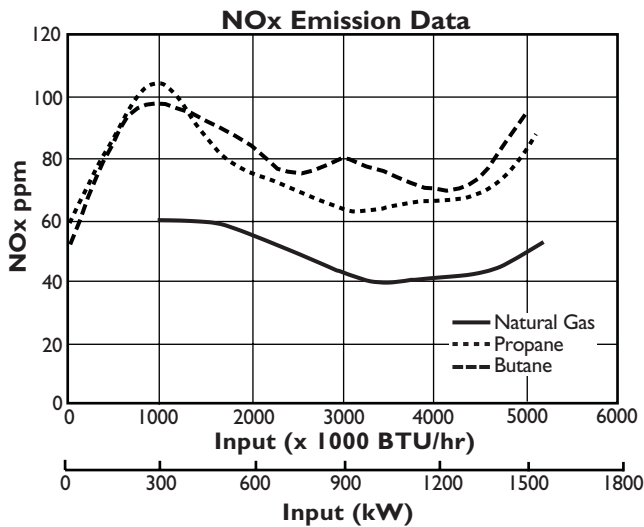

NOx emission data is given for:

- Ambient combustion air ~70°F (20°C)
- Less than 1000°F (538°C firing chamber)
- Minimal process air velocity
- ppm volume dry at 3% O₂
- Neutral chamber pressure

CO emission is largely influenced by chamber conditions. Contact your local Eclipse Combustion representative for an estimate of CO emission on your application.

Emissions are influenced by:

- Chamber conditions
- Fuel type
- Firing rate
- Ratio regulator adjustment
- Combustion air temperature

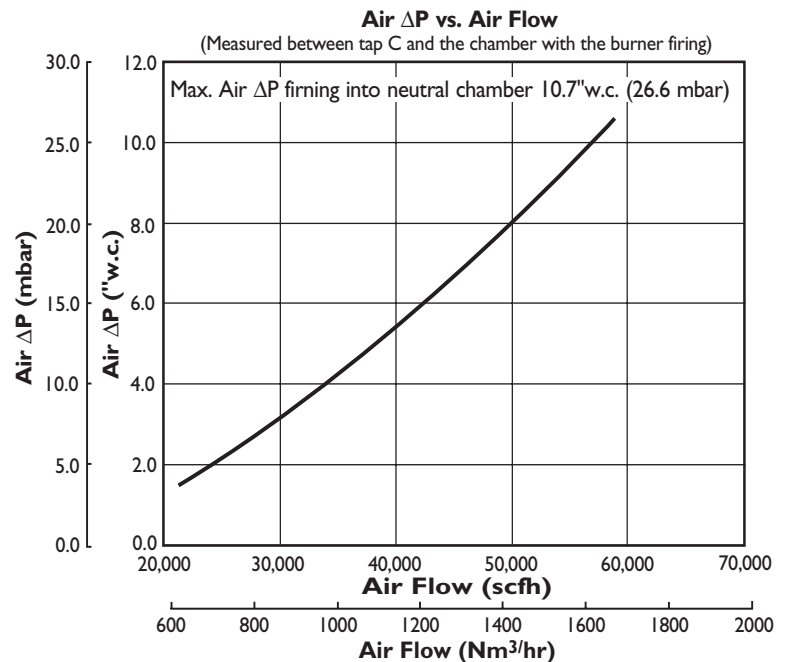
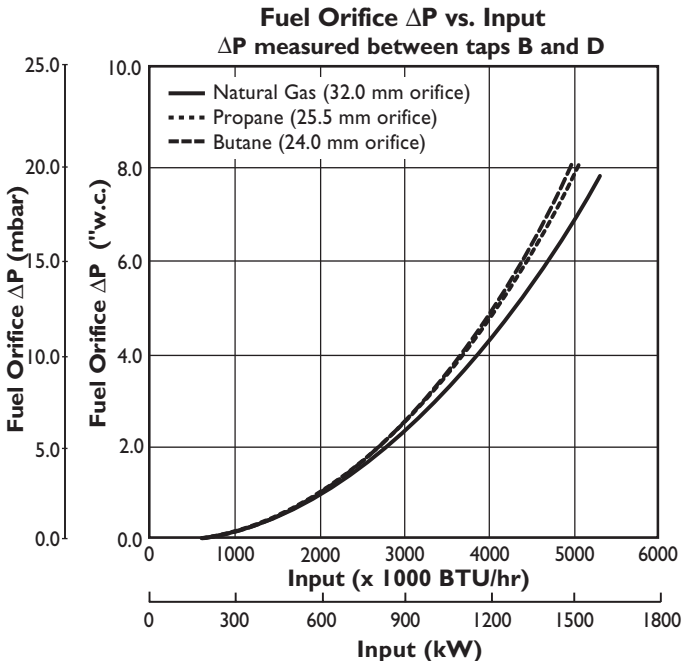

High Velocity Tube Specifications

Blower Model

60Hz, 6D (15" w.c. @ 66,000 scfh, 5 hp)

50Hz, 6D (15" w.c. @ 66,000 scfh, 4 kW)

Specifications						
Parameter	"w.c.	(mbar)	60Hz Packaged Blower		50Hz Packaged Blower	
			Btu/hr	kW	Btu/hr	kW
Maximum Input vs. Chamber Pressure (Natural Gas)	-2.0	-5.0	5,440,000	1593	5,570,000	1630
	-1.0	-2.5	5,288,000	1548	5,410,000	1584
	0.0	0.0	5,100,000	1503	5,250,000	1537
	1.0	2.5	4,970,000	1455	5,080,000	1487
	2.0	5.0	4,804,000	1407	4,910,000	1438

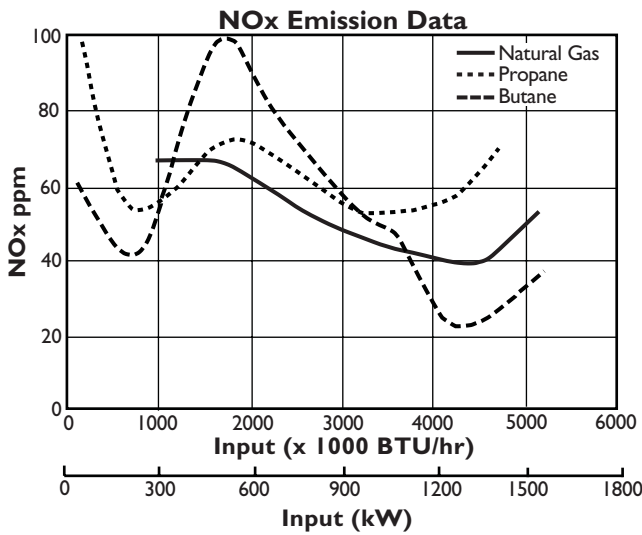

NOx emission data is given for:

- Ambient combustion air ~70°F (20°C)
- Less than 1000°F (538°C firing chamber)
- Minimal process air velocity
- ppm volume dry at 3% O₂
- Neutral chamber pressure

CO emission is largely influenced by chamber conditions. Contact your local Eclipse Combustion representative for an estimate of CO emission on your application.

Emissions are influenced by:

- Chamber conditions
- Fuel type
- Firing rate
- Ratio regulator adjustment
- Combustion air temperature

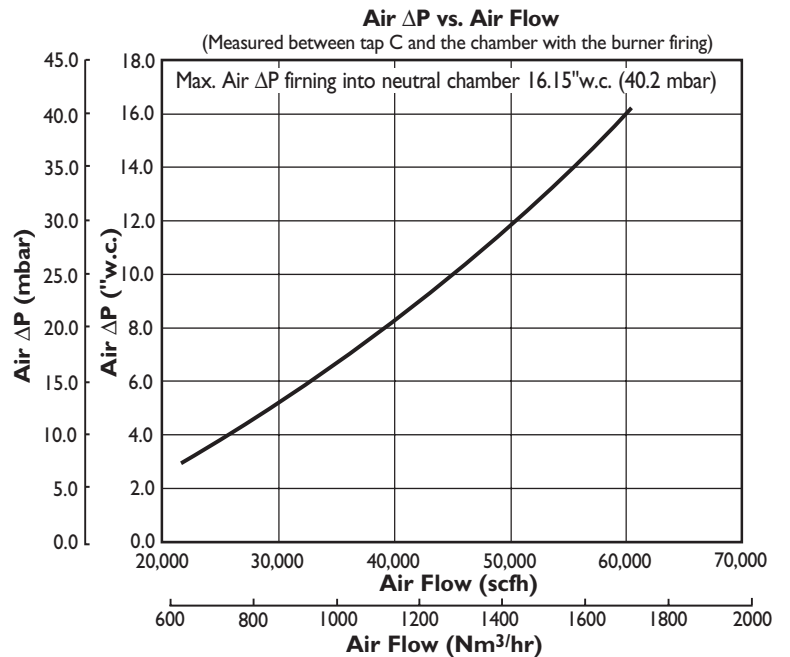
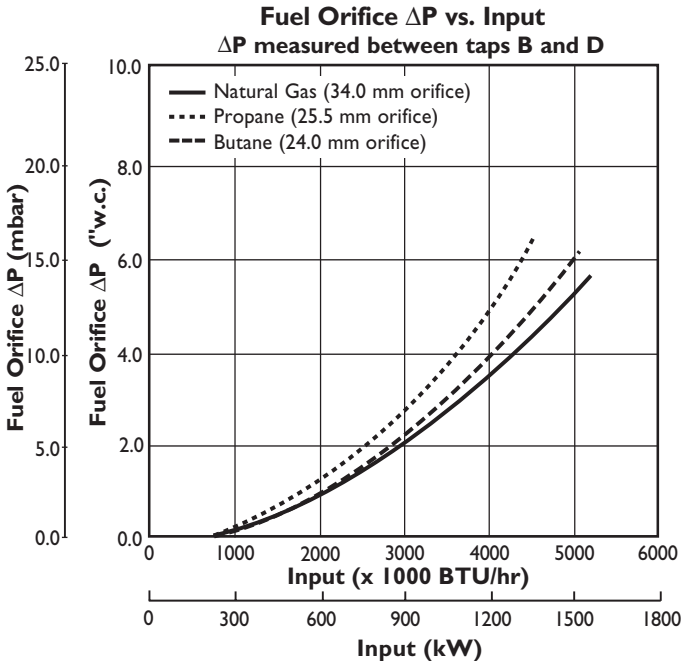

Dimensions mm (Inches)

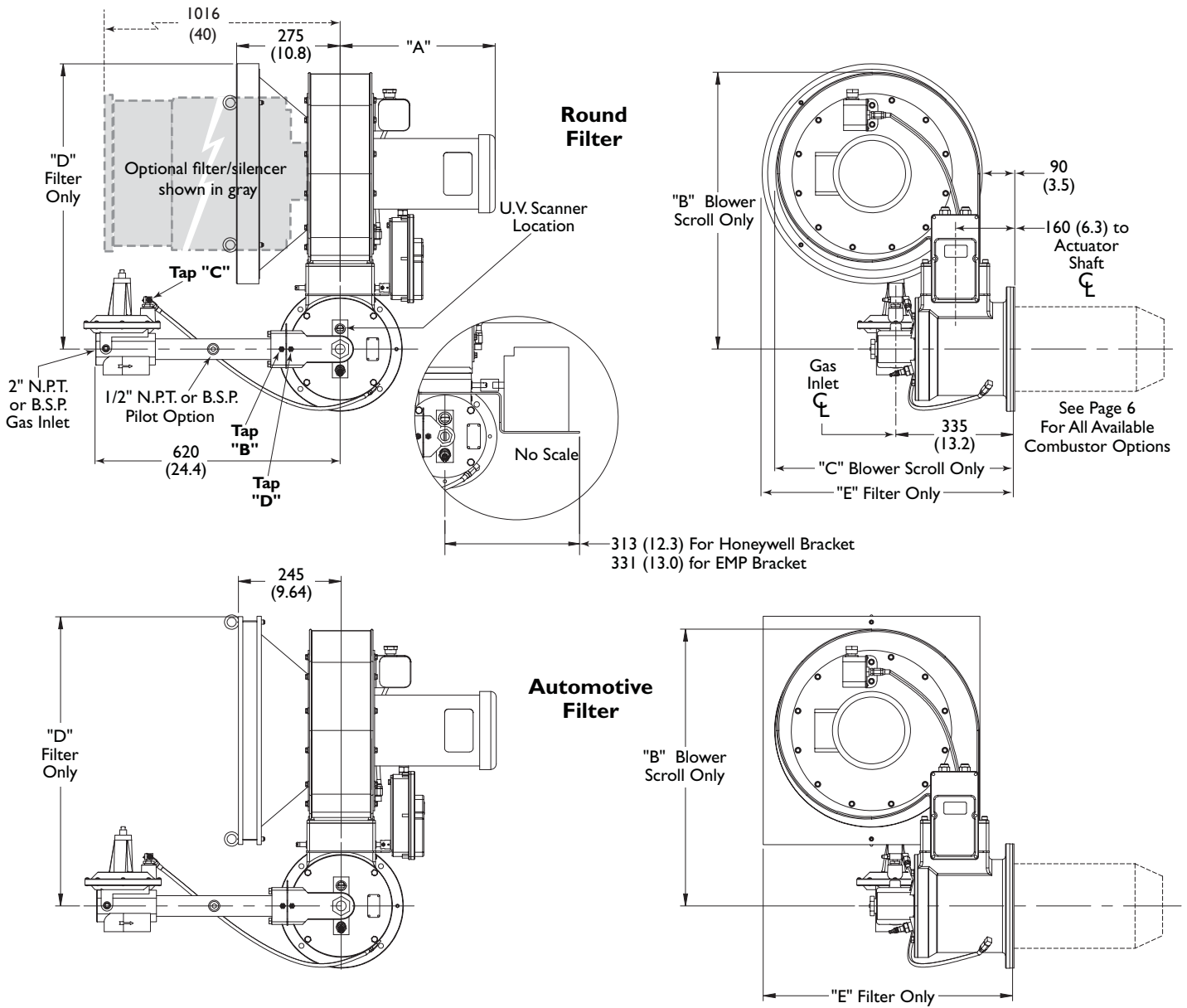

	Combustor Type	Blower Model	Filter Type	Dimensions mm (inches)				
				A	B	C	D	E
60Hz Blower	Straight	6B	Round	368 (14.5)	750 (29.5)	618 (24.3)	832 (32.8)	718 (28.3)
	Medium Velocity	6B	Round	368 (14.5)	750 (29.5)	618 (24.3)	832 (32.8)	718 (28.3)
	High Velocity	6D	Round	427 (16.8)	825 (32.5)	688 (27.1)	872 (34.3)	750 (29.5)
	Straight	6B	Automotive	368 (14.5)	750 (29.5)	618 (24.3)	756 (29.8)	630 (24.8)
	Medium Velocity	6B	Automotive	368 (14.5)	750 (29.5)	618 (24.3)	756 (29.8)	630 (24.8)
	High Velocity	6D	Automotive	427 (16.8)	825 (32.5)	688 (27.1)	784 (30.9)	674 (26.5)
50Hz Blower	Straight & Medium Velocity	6B	Round	427 (16.8)	825 (32.5)	688 (27.1)	872 (34.3)	750 (29.5)
	High Velocity	6D	Round	488 (19.2)	893 (35.2)	698 (27.5)	905 (35.6)	726 (28.6)

Combustor Options

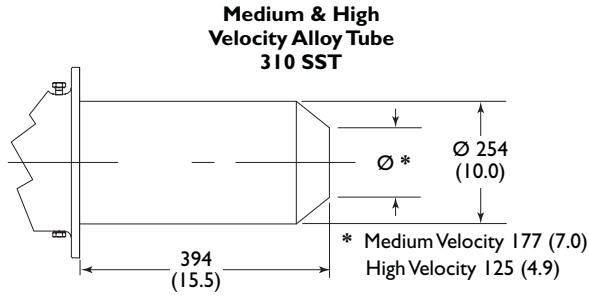
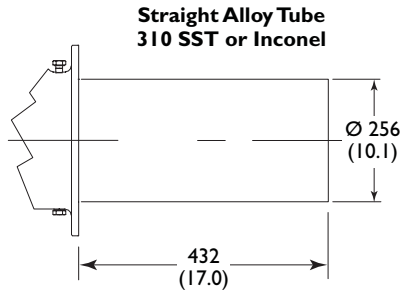

Mounting Pattern

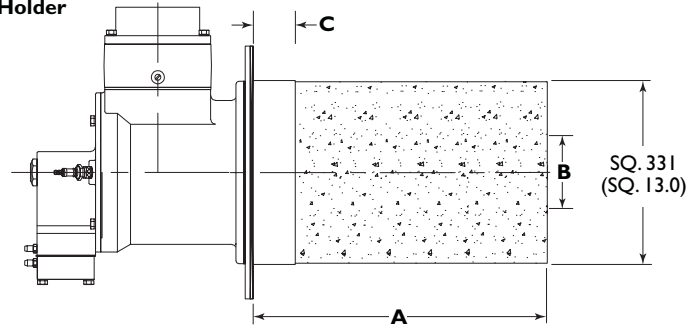
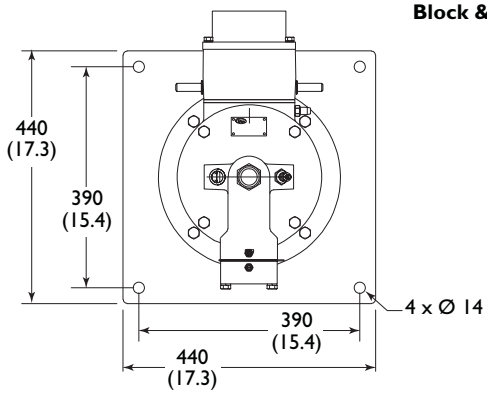
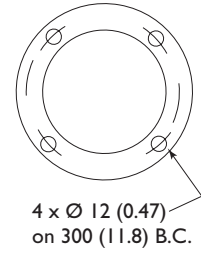

Block & Holder Option	Dimensions mm (Inches)		
	A	B	C
Straight	342 (13.5)	249 (9.8)	317 (12.5)
Medium Velocity	394 (15.5)	177 (7.0)	50 (2.0)
High Velocity	394 (15.5)	125 (4.9)	50 (2.0)

Burner Configuration & Piping Arrangement

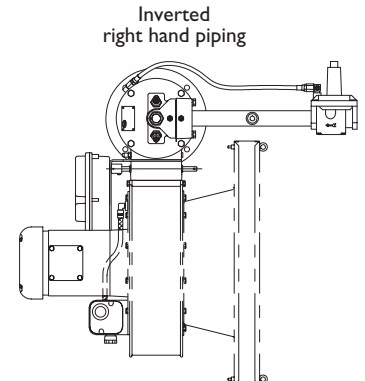
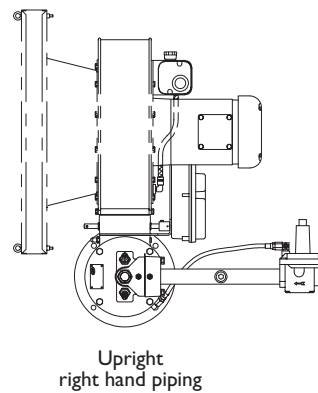
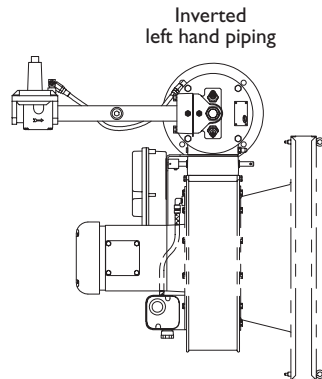
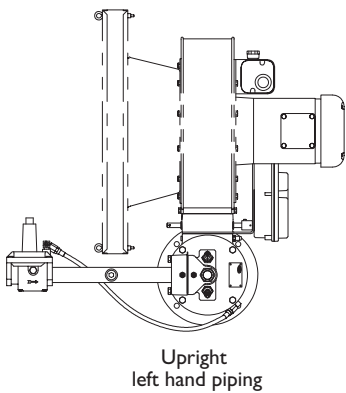



Offered By:

Power Equipment Company
2011 Williamsburg Road
Richmond, Virginia 23231
Phone (804) 236-3800
Fax (804) 236-3882

www.peconet.com